



Technology Solutions

# TEK-BAR 3110A

## Explosion-Proof Differential Pressure Transmitter



PRESSURE



## Introduction

The Tek-Bar 3110A Explosion-Proof Differential Pressure Transmitter have excellent stability, high accuracy, and include features that facilitate easy installation, start up, and minimum maintenance thereby lowering process downtime and overall cost of ownership in the long run. These transmitters are equipped with an automatic temperature compensation function integrated into its advanced signal processing circuitry to ensure high reliability and performance corresponding to change of ambient temperature.

## Measuring Principle

The Tek-Bar 3110A Explosion-Proof Differential Pressure Transmitter uses Capacitance pressure sensors. It consists of two metal plates that are separated by sensing diaphragm. An electrically insulating fill fluid (silicon oil), transfers the movement from isolating diaphragm to the sensing diaphragm. The capacitance characteristics of the sensing element changes. These signal transfer to the electronic circuitry of transmitter that converts the change in capacitance to the output signal. Capacitance transmitters are configured for differential pressure measurement. Usual outputs are voltage or current.

Capacitance can be calculated using the formula:

$$C = \frac{\epsilon(A)}{d}$$

Where,

C- Capacitance,

$\epsilon$ -Dielectric Constant

A-Area of plate

d-Distance between capacitor plates

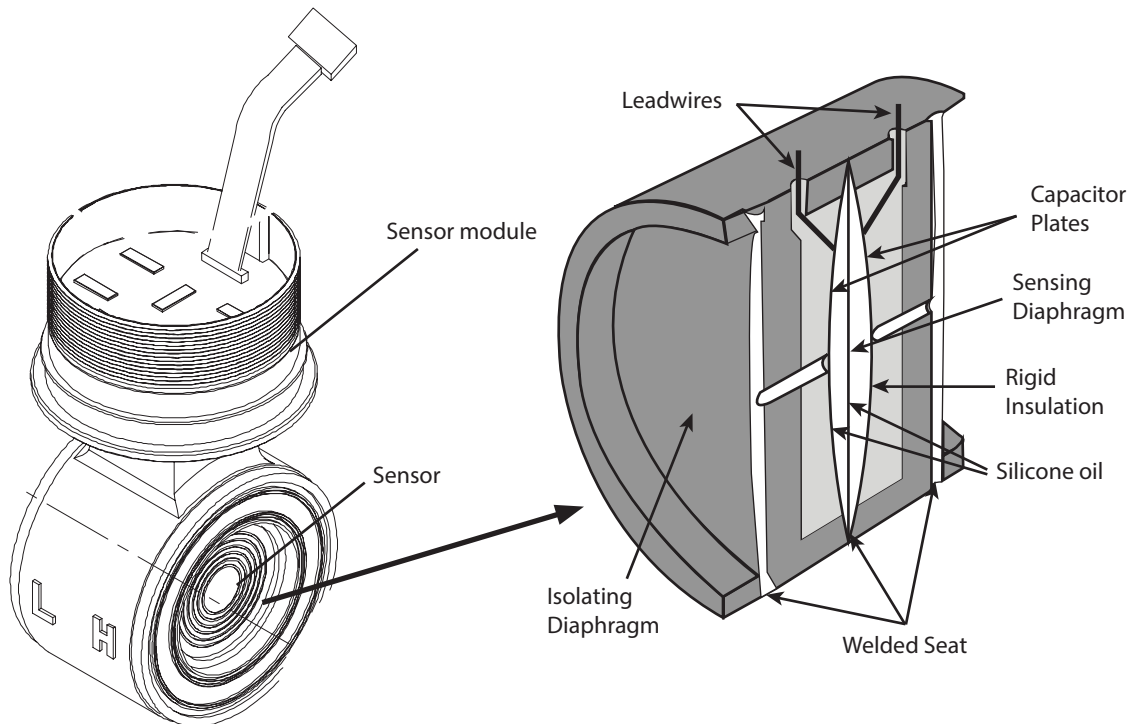

## Operation

### Electronic Module:

The Electronics module consists of a circuit board sealed in an enclosure. It consists of a MCU module, a power module, an analog module, a LCD module and a terminal module. The MCU module acquires the digital value from the analog module and applies correction coefficients selected from EEPROM. The output section of the power module converts the digital signal to a 4 to 20 mA output. The MCU module communicates with the HART based Configurator. The Power module have a DC-to-DC power conversion circuit and an Input/output isolation circuit. An optional LCD module plugs into the MCU module and displays the digital output in the user-configured unit.

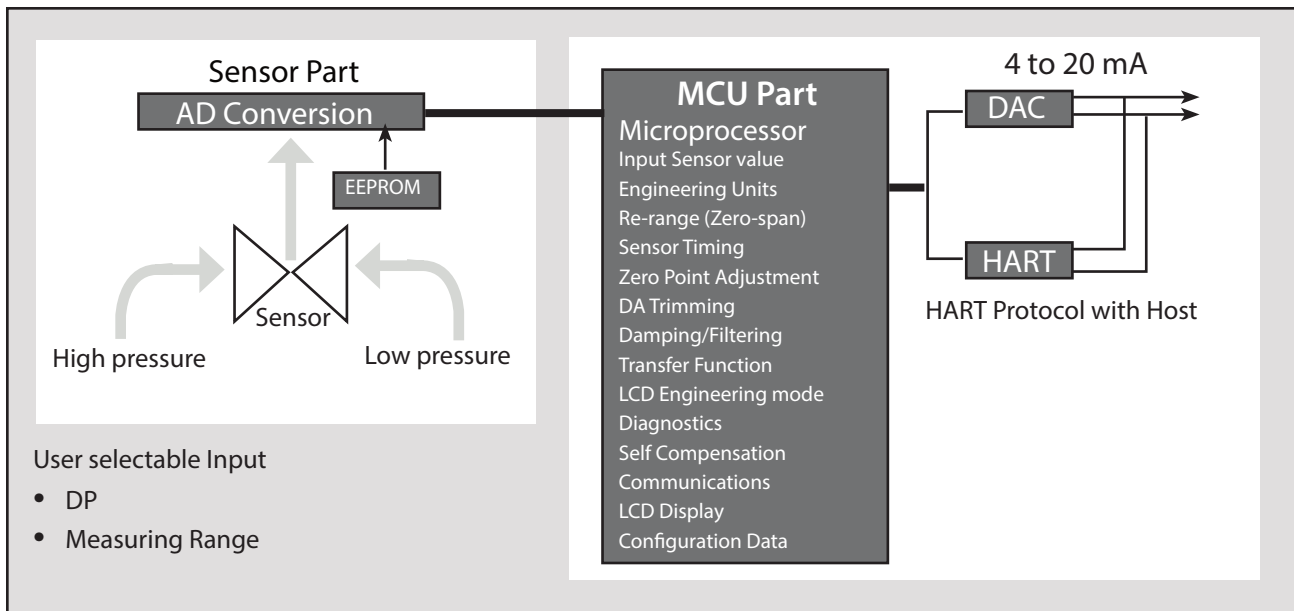

### Sensor Input:

The model Tek-Bar 3110A Explosion-Proof Differential Pressure Transmitter uses capacitance type pressure sensor. The transmitter is used in level and flow applications.

The sensor module converts the capacitance or the resistance to the digital value. The MCU module calculates the process pressure based on the digital value.

The sensor modules include the following features

- The software of the transmitter compensates for the thermal effects, improving performance.
- Precise Input Compensation during operation is achieved with temperature and pressure correction coefficients that are characterized over the range the transmitter and stored in the sensor module EEPROM memory
- EEPROM stores sensor information and correction coefficients separately from MCU module, allowing for easy repair, reconfiguration and replacement

## Features/Benefits

- Operator can calibrate device using zero/span button, no handheld calibrator required
- Digital communication HART protocol
- Fail-safe mode process function for detecting any abnormal condition occurring
- High accuracy up to  $\pm 0.075\%$
- Automatic ambient temperature compensation improve performance of device
- It can be used as flow meter and should be installed vertically without using additional flanges
- Various Output: 4-20 mA, digital signals
- The mounting bracket can be rotated up to  $360^\circ$  and LCD display up to  $270^\circ$
- EEPROM write protection

## Applications

- It can be used as a flowmeter; it can check flow rate and total flow
- Level monitoring
- Used to measure liquid, gas, and steam flow

## Dimensional Drawing

### Standard Model

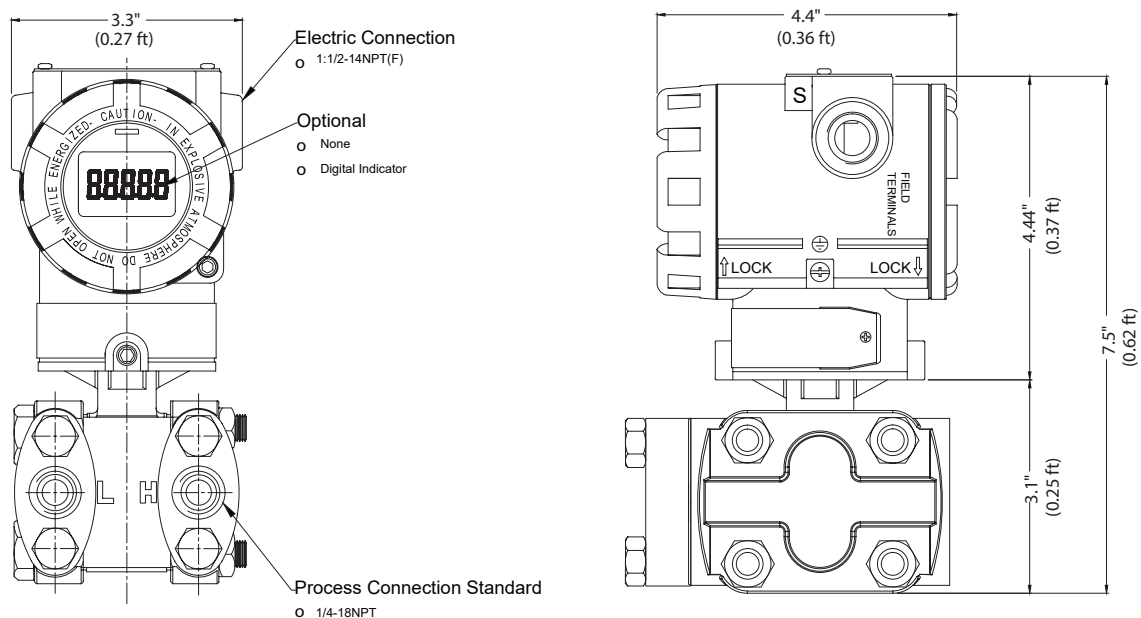

## Specifications

### Technical Specification

Parameter	Description
Accuracy	±0.075% of Span
Turndown	50:1
Stability	±0.125% URL for 36 Months
Maximum Working Pressure Limit	2000 PSI
Process Temperature Limits	-40 °F to +248 °F
Ambient Temperature Effect	±[0.019%URL+0.125% Span] / 82.4 °F
Ambient Temperature	-40 °F to +185 °F
Humidity Limits	5% to 100% RH
Power Supply Effects	±0.005% of Span per Volt
Mounting Position Effects	Zero Shift up to 350Pa No Span Effect
Display (Optional)	5 digit LCD display
Failure Mode	Fail High: Current ≥21.1 mA
	Fail Low: Current ≤3.78 mA
Damping Time	0.25 to 60 sec

### Electrical Specification

Parameter	Description
Power Supply	12 to 45 VDC
HART loop resistance	250 to 550 ohm
Output Signal	4 to 20 mA DC/ HART
Isolation	500 Vrms (707 VDC)

## Physical Specifications

Parameter	Description
Isolating Diaphragm	316LSST
Drain and Vent Valve	316SST
Flange and Adapter	316SST
O-ring	Viton, PTFE
Fill Fluid	Silicone oil or Inert fill
Paint	Epoxy-Polyester or Polyuret
Mounting Bracket	304SST with U-bolt (304SST) for 2-inch pipe
Nameplate	304SST
Electronic Housing	Aluminum (Option:316LSST)
Bolts and Bolting Flange	304SST
Process Connection Size	¼" NPT Female
Electrical Connections	½" NPT Female
Weight (excluding Option Items)	8.589 lb (Standard)
	11.882 lb (SST Housing)
2" Pipe Stanchion Type bracket	Angle or Flat type
Approvals	FM (Class I Div I)

## Measuring Range Limit For Tek-Bar 3110A

Range Code	Calibrated Span (Min. to Max.)		Lower Range Limit		Upper Range Limit	
3	0.6 to 30 in w.c	0.15 to 7.5 kPa	-30 in w.c.	-7.5 kPa	30 in w.c.	7.5 kPa
4	1.5 to 150 in w.c	0.373 to 37.3 kPa	-150 in w.c.	-37.3 kPa	150 in w.c.	37.3 kPa
5	7.5 to 750 in w.c	1.865 to 186.5 kPa	-750 in w.c.	-186.5 kPa	750 in w.c.	186.5 kPa
6	1 to 100 psi	6.9 to 690 kPa	-100 psi	-690 kPa	100 psi	690 kPa
7	3 to 300 psi	20.68 to 2068 kPa	-300 psi	-2068 kPa	300 psi	2068 kPa

## Installation

### Liquid Flow Measurement

- Place taps to the side of the line to prevent sediment deposits on the transmitters process isolators
- Mount the transmitter beside or below the taps so gases can vent into the process line
- Mount drain/vent valve upward to allow gases to vent

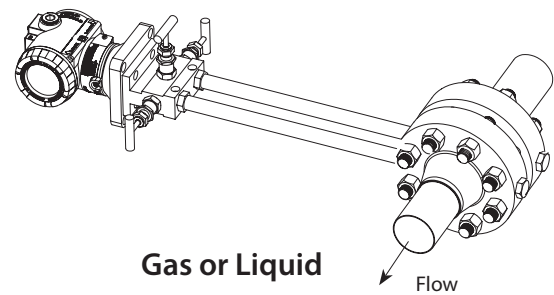

### Gas Flow Measurement

- Place taps in the top or side of the line
- Mount the transmitter beside or above the taps so liquid will drain into the process line

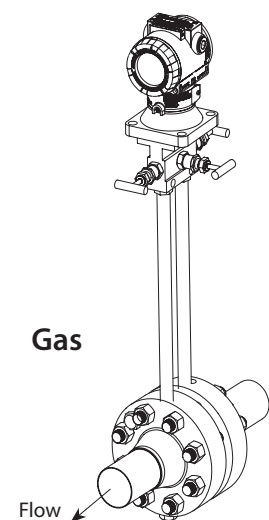

### Steam Flow Measurement

- Place taps to the side of the line.
- Mount the transmitter below the taps to ensure that the impulse piping will stay filled with condensate.
- In steam service above 250 °F (121 °C), fill impulse lines with water to prevent the steam from contacting the transmitter directly and to ensure accurate measurement at start-up.

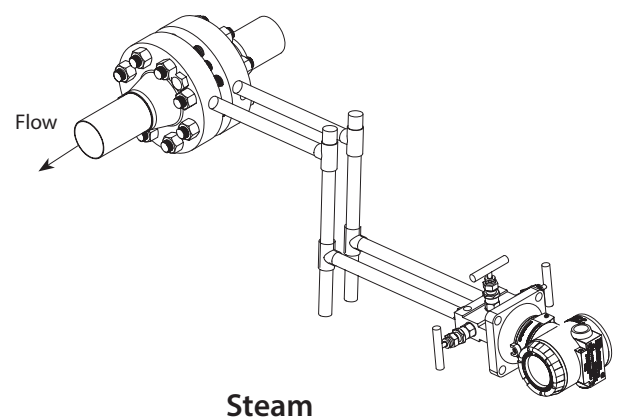

**Note:** For steam or other elevated temperature services, it is important that temperatures at the process connection do not exceed the transmitters process temperature limits.

## Model Chart

<b>Example</b>	Tek-Bar 3110A-D	3	FM	1	1	LCD	Tek-Bar 3110A-D-3-FM-1-1-LCD
<b>Series</b>	Tek-Bar 3110A-D						Explosion-Proof Differential Pressure Transmitter
<b>Range Options</b>		3 4 5 6 7					0-30" w.c. 0-150" w.c. 0-750" w.c. 0-100 psid 0-300 psid
<b>Approval Rating</b>			FM				FM Approval (Class I Div I)
<b>Process Connections</b>				1 X			¼" NPT Female Diaphragm Seal
<b>Electrical Connection</b>					1		½" NPT Female
<b>Options</b>						LCD MFI SSH CC FC BA BF TAG LP LV O	5 Digit LCD (Local Indication Only) Multi Funtional Indicator (With advanced local UI/UX) 316 Stainless Steel Housing Custom Calibration with 5 point Callibration Certificate Factory Configuration, No Certificate (Need customer range) Stainless Steel Bracket (Angle type) with SST Bolts Stainless Steel Bracket (Flat type) with SST Bolts Custom etching of the name plate (Must specify on P.O.) Lighting Protection 12 VDC, Low Volt, 4-wire, 1-5 VDC output, No HART (Must include option MFI) ½"-14 NPTF, Oval Flange Process Connection Adapter (Includes 2 O-Rings, an adapter, and 2 bolts)

## Popular Models

Model Number	Description
3110A-D-3-FM-1-1-LCD	Explosion-proof DP Pressure Transmitter, 0-30" w.c., LCD
3110A-D-4-FM-1-1-LCD	Explosion-proof DP Pressure Transmitter, 0-150" w.c., LCD
3110A-D-5-FM-1-1-LCD	Explosion-proof DP Pressure Transmitter, 0-750" w.c., LCD
3110A-D-6-FM-1-1-LCD	Explosion-proof DP Pressure Transmitter, 0-100 psid, LCD
3110A-D-7-FM-1-1-LCD	Explosion-proof DP Pressure Transmitter, 0-300 psid, LCD



# Customer Service and Support



TEKMATION LLC reserves the right to change the designs and/or materials of its products without notice. The contents of this publication are the property of TEKMATON and cannot be reproduced by any other party without written permission. All rights reserved. Copyright © 2016 TEKMATON LLC  
TEKMATION LLC  
DOC # TEK/AK/1801/29/TEK-BAF/101



[www.tek-trol.com](http://www.tek-trol.com)

Tek-Trol is a fully owned subsidiary of TEKMATON LLC. We offer our customers a comprehensive range of products and solutions for process, power, and oil and gas industries. Tek-Trol provides process measurement and control products for Flow, Level, Temperature and Pressure Measurement, Control Valves and Analyzer systems. We are present in 15 locations globally and are known for our knowledge, innovative solutions, reliable products, and global presence.

## **Tek-Trol LLC**

796 Tek Drive Crystal Lake, IL 60014 USA

Tel: +1 847 857 6076, +1 847 655 7428 Fax: +1 847 655 6147

Email: [tektrol@tek-trol.com](mailto:tektrol@tek-trol.com)

[www.tek-trol.com](http://www.tek-trol.com)