



Technology Solutions

TEK-BAR 3800E

Utilities/Non-Explosion Proof Multivariable Transmitter



PRESSURE



Introduction

Tek-Bar 3800E is an advanced Utilities/Non-Explosion Proof Multivariable Transmitter designed for simultaneous measurement of multiple independent process variables. The device is suitable in a wide range of liquid, gas, and steam applications for measuring static pressure, differential pressure, temperature, and mass flow. The Tek-Bar 3800E is highly stable with accurate sensors offering unprecedented performance in terms of accuracy, repeatability, and reliability.

Tek-Bar 3800E displays output on its local indicator as well as supports HART communication protocol for remote set-up and control. Delivering simultaneous real-time measurements, this device is capable of instantaneous and cumulative mass flow calculations and data acquisition. Additional features include easy set-up, quick response-time, self-diagnostics and alarm indicators.

The Tek-Bar 3800E offers precise and reliable measurements in harsh environments due to its fully welded construction. It has the capability to measure multiple variables with one transmitter, thus minimizing pipe penetrations, wiring costs and installation time.

Measuring Principle and Operation

Tek-Bar 3800E Utilities/Non-Explosion Proof Multivariable Transmitter consists of two functional units: - Main Unit and Auxiliary Unit.

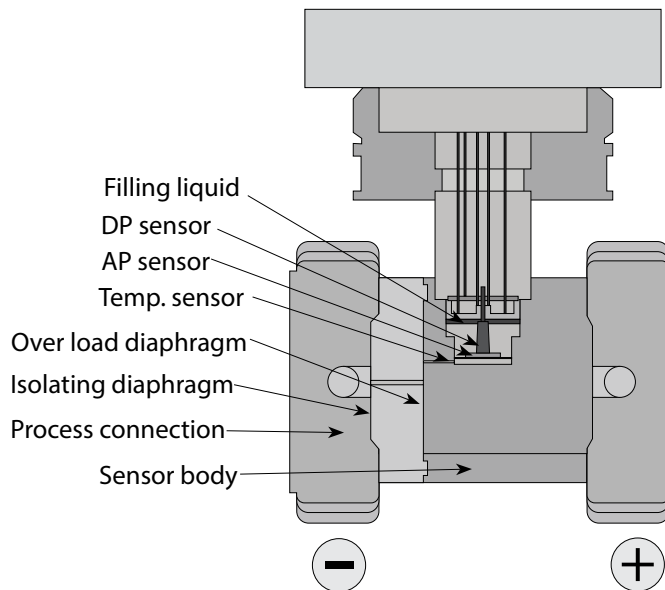

The main unit is composed of sensors and process connections. The completely sealed dual-chamber sensor module comprises of an overload diaphragm, absolute pressure sensor, differential pressure sensor and temperature sensor.

The differential pressure sensor senses the pressure across a primary flow element such as an orifice plate, flow nozzle, venturi etc. The absolute pressure sensor acts as a reference value to compensate for static pressure, hence is only exposed to the higher-pressure side. The temperature is measured by a standard 100 Ω RTD. The temperature sensor also acts as a temperature compensated reference value to compensate for the temperature drift. The auxiliary unit includes a terminal block, power supply and HART communicator.

The advanced software of the transmitter allows further complex calculations such as mass flow, density, and level measurement of the process fluid. These calculations are compensated against drifts in discharge coefficient, viscosity, thermal expansion factor, and gas expansion factor. Located at the top of the metal body, away from the process fluid, the sensor module is mechanically and thermally isolated.

Benefits

- Suitable for wide range of media such as steam, liquid, general gas
- Fully sealed sensor encapsulation for harsh environment
- Protected against severe pressure and temperature spikes
- Optional LCD display with convenient push buttons for configuration
- 4-20 mA or RS485 protocol enabled
- Convenient 360° rotatable display module
- High accuracy up to $\pm 0.075\%$ FS

Applications

- Steam
- Medical or pharmaceutical
- Engine control, pneumatic hydraulic machines
- Chemical and petrochemical
- Air conditioning, refrigeration systems
- Water and wastewater
- Power Plants

Dimensional Drawing

Horizontal Impulse Piping Type (Side face)

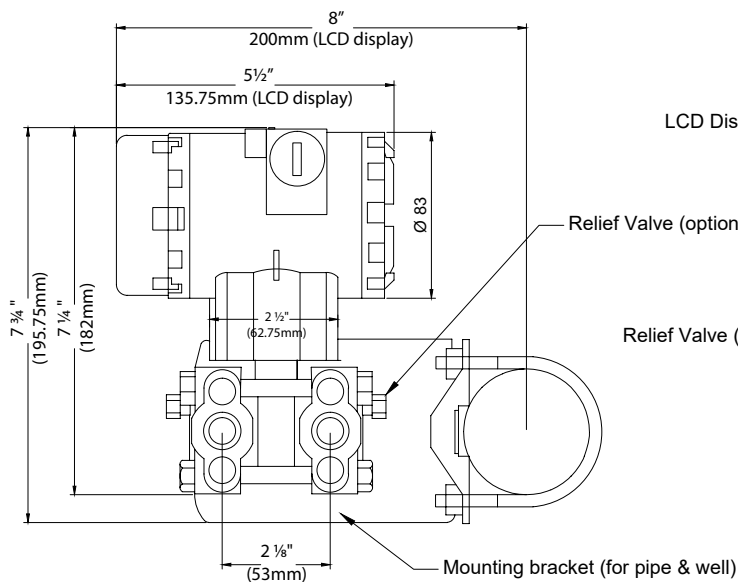

Horizontal Impulse Piping Type (Front side)

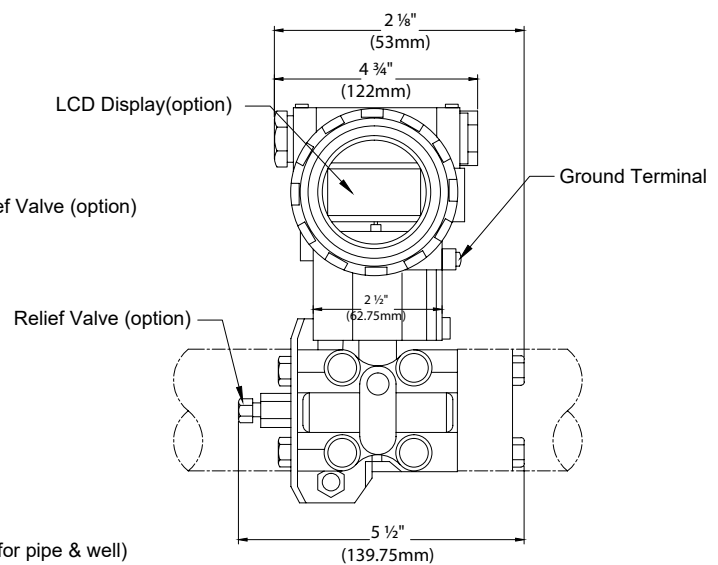

Horizontal Impulse Wall Mounting Type

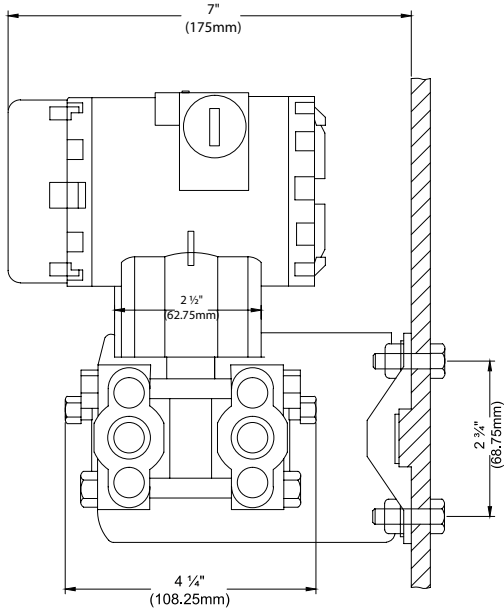

Vertical Impulse Piping Type

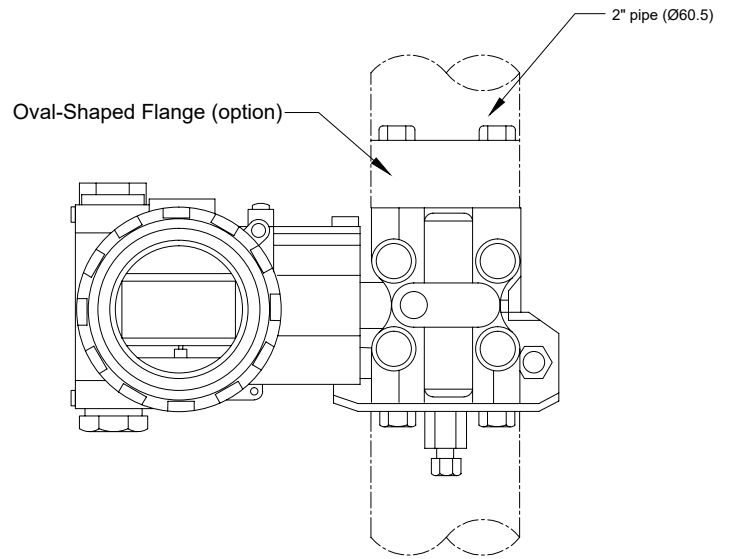

Specification

Physical Specification

Wetted Parts Materials	
Sensor Body	316 SS
Isolating Diaphragm	316 SS or Hastelloy C
Cover Flange	316 SS
Nuts and Bolts	304 SS
Process Connector	316 SS
Fill Fluid	Silicone Oil or Fluorinated Oil
Process Connector Gasket	Fluoroelastomer (FKM) or Polytetrafluoroethylene (PTFE)
Amplifier Housing	Aluminum with epoxy resin coat
Housing Gasket	NBR
Name Plate and Tag	304 SS
Protection	IP67
Weight	7.27 lb (3.3 Kg)
Connections	
Process Connections	1/4" Female NPT, Relief valve
Electrical Connections	1/2" NPT conduit connections

Electrical Specification

Power Supply (Vs)	24 VDC
Load Resistance (R _L)	$R_L \leq (U_s - 12 \text{ V}) / I_{\text{max}}$ kΩ
Maximum Current (I _{max})	23mA
Output	2-wire 4-20mA, Modbus RS485 or Pulse

Performance Specification

Reference Accuracy	± 0.075% FS
Long Term Stability	±0.1% FS for 3 years
Over Pressure	±0.1% FS for 10 MPa
Measuring Temperature	-58 °F to 1202 °F (-50 °C to 650 °C)
Ambient Temperature	-40 °F to 185 °F (-40 °C to 85 °C)
Storage Temperature	-40 °F to 185 °F (-40 °C to 85 °C) -58 °F to 185 °F (-50 °C to 85 °C)
Maximum Working Pressure	0.25 Mpa, 2 Mpa, 10 Mpa, 40 Mpa
Response Time	0.1-1.6 sec.

Functional Specification

Span and Range Limits for DP sensor			
Span	Min of Span	Max of Span	Working Pressure
B	0" w.c. (0 Pa)	24" w.c. (6 kPa)	0.25/2/10/40 MPa (36/290/1450/5800 psi)
C	0" w.c. (0 kPa)	160" w.c. (40 kPa)	2/10/40 MPa (290/1450/5800 psi)
D	0" w.c. (0 kPa)	1000" w.c. (250 kPa)	2/10/40 MPa (290/1450/5800 psi)
E	0 psid (0 kPa)	290 psid (2 Mpa)	2/10/40 MPa (290/1450/5800 psi)
Span of Static Pressure Sensor			
Span		Working Pressure	
1	36 psi (0.25 MPa)	36 psi (0.25 MPa)	
2	290 psi (2 Mpa)	290 psi (2 Mpa)	
3	1450 psi (10 MPa)	1450 psi (10 MPa)	
4	5800 psi (40 MPa)	5800 psi (40 MPa)	

Installation

- Ensure that the operating staff handling the pressure instrument is professionally trained
- The transmitter should be direct-mounted to an instrument manifold or secured to a pipe or wall
- Depending on application, install the transmitter vertically / horizontally, directly on the impulse lines or on the wall using mounting brackets
- Rotate the electronic housing (360° capable) to a comfortable position
- While fitting the connections, ensure that the torque meets maximum pressure rating requirements
- Avoid sediment deposition in impulse piping
- In case of liquid applications, vent all gas from piping legs and avoid trapped air
- Ensure there are no pressure leakage points in the connection
- Maintain equal head pressure on both legs of impulse piping

Liquid Flow

Place taps on the side and mount the transmitter beside or below the taps. Ensure that the drain / vent valves are oriented upwards.

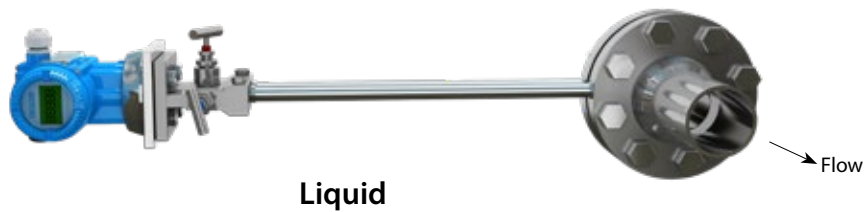

Gas Flow

Place taps on the top of the line and mount the transmitter above the taps.



Steam Flow

Use impulse lines to place the transmitter away from the line. Place taps on the side of the line. Mount the transmitter beside or below the taps. Fill impulse lines with water at start-up.

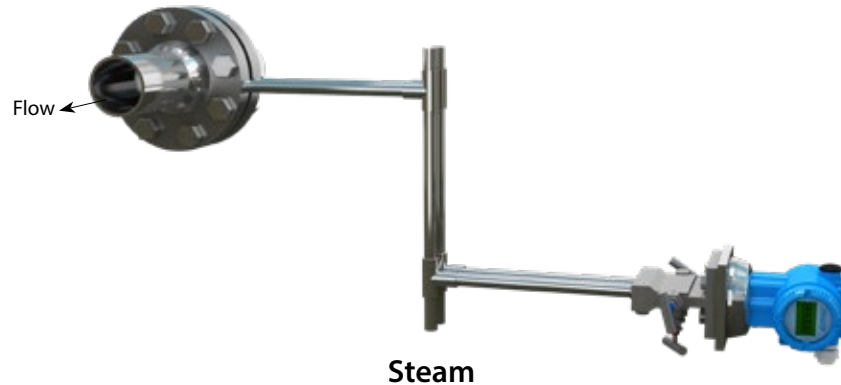

Model Chart

Example	Tek-Bar 3800E	B	C	3	A	B	F	1	BF	Tek-Bar 3800E-B-C-3-A-B-F-1-BF
Series	Tek-Bar 3800E									Utilities/Non-Explosion Proof Multivariable Transmitter
Accuracy		B								± 0.075% FS
Differential Pressure Range			B C D E							0 to 24" w.c. (0 to 6 kPa) 0 to 160" w.c. (0 to 40 kPa) 0 to 1000" w.c. (0 to 250 kPa) 0 to 290 psid (0 to 2 MPa)
Static Pressure Range				1 2 3 4						0 to 36 psi (0 to 0.25 MPa) 0 to 290 psi (0 to 2 MPa) 0 to 1450 psi (0 to 10 MPa) 0 to 5800 psi (0 to 40 MPa)
Diaphragm and Fill Fluid					A B C D					316 Stainless Steel, Silicone Oil 316 Stainless Steel, Fluorinated Oil Hastelloy C, Silicone Oil Hastelloy C, Fluorinated Oil
Process Connection						B				¼" Female NPT, Relief Valve
Process Gasket							F P			Fluoroelastomer (FKM) PTFE
LCD Display								1 N		LCD Display No LCD Display
Options									BF O FC TAG CC	304SS Mounting Bracket ½" NPT Oval Flange Process Connection Adaptors Factory Configuration Custom Nameplate NIST Calibration, 5 Points

Customer Service & Support



TEKMATION LLC reserves the right to change the designs and/or materials of its products without notice. The contents of this publication are the property of TEKMATON and cannot be reproduced by any other party without written permission. All rights reserved. Copyright © 2021 TEKMATON LLC
DOC # TEK/PO/210701/3800E/003
TEKMATION LLC



www.tek-trol.com

Tek-Trol LLC

796 Tek Drive Crystal Lake, IL 60014,
USA
Sales: +1 847-857-6076

Tek-DPro Flow Solutions

PO Box 121 Windsor, Colorado 80550,
USA
Sales: +1 847-857-6076

Tek-Trol Solutions BV

Florijnstraat 18, 4879 AH Etten-Leur,
Netherlands
Sales: +31 76-2031908

Tek-Trol Middle East FZE

SAIF Zone, Y1-067, PO BOX No.
21125, Sharjah, UAE
Sales: +971-6526-8344

Support: +1 847-857-6076

Email: tektrol@tek-trol.com

www.tek-trol.com

Tek-Trol is a fully owned subsidiary of TEKMATON LLC. We offer our customers a comprehensive range of products and solutions for process, power and oil & gas industries. Tek-Trol provides process measurement and control products for Flow, Level, Temperature & Pressure measurement, Control valves & Analyzer systems. We are present in 15 locations globally and are known for our knowledge, innovative solutions, reliable products and global presence.