



TEK-DP1650A

DProbar

Multiport Self-Averaging Flow Meter

Instruction Manual

Document Number: IM-1650A

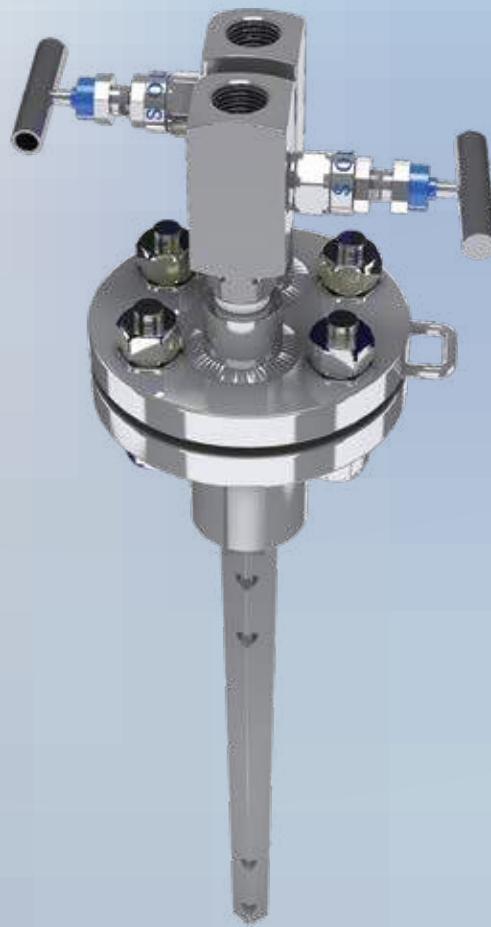

www.tek-trol.com

NOTICE

Read this manual before working with the product. For personal and system safety, and for optimum product performance, make sure you thoroughly understand the contents before installing, using, or maintaining this product.

For technical assistance, contact

Customer Support

796 Tek-Drive

Crystal Lake, IL 60014

USA

Tel: +1 847 857 6076

© **COPYRIGHT Tek-Trol LLC 2021**

No part of this publication may be copied or distributed, transmitted, transcribed, stored in a retrieval system, or translated into any human or computer language, in any form or by any means, electronic, mechanical, manual, or otherwise, or disclosed to third parties without the express written permission. The information contained in this manual is subject to change without notice.

Table of Contents

1	Safety Instructions.....	2
1.1	Intended Use	2
1.2	Safety Instructions from the Manufacturer.....	2
1.2.1	Disclaimer.....	2
1.2.2	Product Liability and Warranty	2
1.2.3	Information Concerning the Documentation.....	2
1.3	Safety Precautions	2
1.4	Packaging, Transportation and Storage	3
1.4.1	Packaging.....	3
1.4.2	Transportation.....	3
1.4.3	Storage	4
1.4.4	Nameplate.....	4
2	Product Description	4
2.1	Introduction	4
2.2	Measuring Principle	4
2.3	Dimensional Drawings	5
2.4	Specifications	6
2.5	Model chart.....	6
3	Installation	8
3.1	Selection of Installation of Locations	9
3.1.1	NPE FBR-61 FLUID BAR	9
3.1.2	TYPE FBR-73 & FBR-75 FLUID BAR.....	10
3.1.3	TYPE FBR-76 FLUID BAR.....	10
3.1.4	TYPE FBF-61 FLUID BAR	11
3.1.5	TYPE FBF-75 & FBF-76 FLUID BAR	11
3.1.6	TYPE FBF-85 FLUID BAR	11
3.1.7	TYPE FTL-73, FTL-75 & FTL-76 FLUID BAR.....	12
3.2	Installation Procedure.....	12
4	Electrical Connection	13
4.1	Grounding of Measuring Device	14
5	Troubleshooting	14

1 Safety Instructions

1.1 Intended Use

Tek-DP 1650A DProbar Multiport Self-Averaging Flow Meter measures the average pressure by taking sample values at different points in the pipe.

1.2 Safety Instructions from the Manufacturer

1.2.1 Disclaimer

The manufacturer will not be held accountable for any damage that happens by using its product, including but not limited to direct, indirect, or incidental and consequential damages. Any product purchased from the manufacturer is warranted in accordance with the relevant product documentation and our Terms and Conditions of Sale.

The manufacturer has the right to modify the content of this document, including the disclaimer, at any time for any reason without prior notice, and will not be answerable in any way for the possible consequence of such changes.

1.2.2 Product Liability and Warranty

The operator shall bear authority for the suitability of the device for the specific application. The manufacturer accepts no liability for the consequences of misuse by the operator. Wrong installation or operation of the devices (systems) will cause the warranty to be void. The respective Terms and Conditions of Sale, which form the basis for the sales contract shall also apply.

1.2.3 Information Concerning the Documentation

To prevent any injury to the operator or damage to the device it is essential to read the information in this document and the applicable national standard safety instructions. This operating manual contains all the information needed in various stages, such as product identification, incoming acceptance and storage, mounting, connection, operation, and commissioning, troubleshooting, maintenance, and disposal.

1.3 Safety Precautions

You must read these instructions carefully before installing and commissioning the device. These instructions are an important part of the product and must be kept for future reference. Only by observing these instructions, optimum protection of both personnel and the environment, as well as safe and fault-free operation of the device can be ensured.

For additional information that is not discussed in this manual, contact the manufacturer.

Warnings and Symbols Used

The following safety symbol marks are used in this operation manual and on the instrument.



WARNING

Indicates a potentially hazardous situation which, if not avoided, could result in death or severe injury



CAUTION

Indicates a potentially hazardous situation which, if not avoided, may result in minor or moderate injury. It may also be used to alert against unsafe practices.



NOTE

Indicates that operating the hardware or software in this manner may damage it or lead to system failure.

1.4 Packaging, Transportation and Storage

1.4.1 Packaging

The original package consists of

1. Tek-DP 1650A DProbar Multiport Self-Averaging Flow Meter
2. Documentation



NOTE

Unpack and Check the contents for damages or sign of rough handling. Report damage to the manufacturer immediately. Check the contents against the packing list provided.

1.4.2 Transportation

- Avoid impact shocks to the device and prevent it from getting wet during transportation.
- Verify local safety regulations, directives, and company procedures with respect to hoisting, rigging, and transportation of heavy equipment.
- Transport the product to the installation site using the original manufacturer's packing whenever possible.

1.4.3 Storage

If this product is to be stored for a long period of time before installation, take the following precautions:

- Store your product in the manufacturer's original packing used for shipping.
- Storage location should conform to the following requirements:
 1. Free from rain and water
 2. Free from vibration and impact shock
 3. At room temperature with minimal temperature and humidity variation
- Before storing a used flowmeter remove any fluid from the flowmeter line completely. Properties of the instrument can change when stored outdoors.

1.4.4 Nameplate

The nameplate lists the order number and other important information, such as design details and technical data.



NOTE

Check the device nameplate to ensure that the device is delivered according to your order. Check for the correct supply voltage printed on the nameplate.

2 Product Description

This section covers the reference and specification data, as well as ordering information.

2.1 Introduction

The Tek-DP 1650A DProbar Multiport Self-Averaging Flow Meter functions as an obstruction that changes the cross-section of the flow of the liquid in the pipe or conduit. In a differential pressure flow meter, as the liquid passes through the obstruction, its potential energy is converted into kinetic energy. The velocity of the liquid increases and is accompanied by a simultaneous decrease in the pressure. When the liquid exits the obstruction, the velocity decreases, and the pressure increases again. These pressure drops generated across the obstacle are proportional to the flow rate square and calculated using Bernoulli's equation.

2.2 Measuring Principle

While the Tek-DP 1650A DProbar measures the pressure of a liquid at a single point, the more modern averaging Tek-DP 1650A DProbar measures the average pressure by taking sample values at different points in the pipe. It is inserted directly into the pipe and is perpendicular to the direction of flow. The side of the tube facing the flow of the liquid consists of several impact pressure ports while the opposite side of the tube may have a single or multiple static pressure ports. These ports are connected together to a secondary device such as a differential pressure transmitter.

When the liquid comes in contact with the tube, the kinetic energy of the liquid is converted into potential energy and velocity is reduced to zero. The pressure now measured at the upstream ports is called the total impact pressure, which is the sum of the static pressure and the dynamic

pressure of the liquid. The impact pressure is directly proportional to the flow rate of the liquid. As the liquid flows around the Tek-DP 1650A DProbar, the static pressure ports measure the decrease in pressure downstream of the flow. These pressure differentials are then averaged to determine the flow rate of the liquid using the following formulas:

To calculate the volumetric flow rate:

$$Q_A = N * K * D^2 * F_{aa} * (\sqrt{DP/G_F}) \quad (\text{For liquids})$$

$$Q_A = N * K * D^2 * F_{aa} * (\sqrt{DP/\rho_F}) \quad (\text{For gases})$$

To calculate the mass flow rate:

$$Q_{MASS} = N * K * D^2 * Y_a * F_{aa} * \sqrt{(P*DP)/T} \quad (\text{For gases and steam})$$

2.3 Dimensional Drawings

- Permanently Installed Type

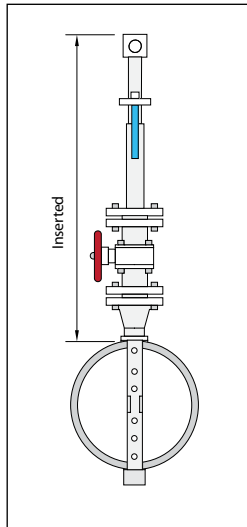

Fig 1: Fixed Dimensions

- Retractable Type

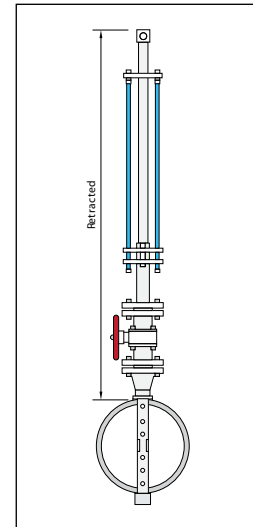

Fig 2: Retracted Dimension

***Note:** Dimensions are subject to vary at time of manufacturing based on final Beta selected. Dimensional drawing with a final engineering sizing sheet will be provided within 1-2 weeks of order acceptance.

2.4 Specifications

Accuracy	± 1 % with 95 % confidence
Process Media	Liquid, Gas, and Steam
Line Sizes	2" to 72"
Sizes	3/25/60 mm
Operating Temperature	Standard at -20°F to 100°F, optional -40°F to 1200°F
Material	316L SS 304L SS
Valve Material	316 SS Carbon Steel
DProbar Material	All standard materials available including Brass, steel, stainless steel and Hastelloy
Bolt Material	ASTM A193 B7 / ASTM A194 2H ASTM A193 B8M / ASTM A194 8MA
Process Connection	Flanged Weld prepared ends Threaded BSPT Threaded NPT Others on request
Mounting	Flanged ball and gate access valve

2.5 Model chart

Example	Tek-DP 1650A	F	G	100	S	01	A	02	A	B	O	01	#	TEK-DP 1650A-F-G-100-S-01- A-02-A-B-O-01
Series	Tek-DP 1650A													DProbar Multiport Self-Averaging Flow Meter
Type		F												Fixed
Media			L G S											Liquid Gas Steam
Size				050 065 080 085 100 125 150 175 200 250 300 350 400										2" 2 ½" 3" 3 ½" 4" 5" 6" 7" 8" 10" 12" 14" 16"

				450														18"
				500														20"
				600														24"
				750														30"
Meter Body					S													316 SS
Pipe Schedule						01												STD (Standard Pipe SCH)
						02												10S
						03												10
						04												20
						05												30
						06												40S
						07												40
						08												80S
						09												80
						10												120
						11												160
						12												XS
						13												XXS
						XX												Special
Transmitter Connection									A									Remote mount; NPT connection
Pressure Rating										01								Threaded Connection (300psi)
										02								150# RF ANSI
										XX								Special
Pipe Fitting Material (Weld and Thread)											A							316SS
											X							Special
Process Connections												A						1-½" mNPT
												B						1-½" 150# Flange
												C						1-½" weldolet
Temperature Measurement													O					No Temperature Sensor
													T					Integral RTD
													X					Remote thermowell and RTD
Flow Transmitters / Computers															01			None (Customer Supplied)
															02			Tek-Bar 3110 (Liquids) - Smart DP
															03			Tek-Bar 3800 (MVT Steam & Compressed Gases)
															04			Tek-FC 8000 (Natural Gas - Flow Computer)
															05			TekValsys DPRO (Insitu Flow Validation)
															06			TekValsys DPRO WFGM (Wet Gas)
															XX			Special
Options																MTR		Material Test Report EN3.1
																MC		Material Cert EN2.1
																COC		Certificate of Conformity
																O2C		O2 Cleaned
																TAG		SS TAG PLATE
																CDE		Certified Drawing Electronic (As Built)
																MRB		Manufacturing Record Book
																DFT		Dry Film Thickness - Custom Paint Spec

Improper installation has the potential to cause injury and to damage instrument. Periodically inspect the power cables, transducer cables, cable glands and the enclosure for signs of damage. Inspect transducer installation and mounting hardware for loose connections.

3.1 Selection of Installation of Locations

- Correct location of the Fluid Bar in the pipeline is important because disturbance in flow produced by the pipe layout may affect the accuracy of measurement. The following standard practices should be reviewed before selecting a mounting location.
- **Straight Run Requirements**
The minimum straight length requirement between various fittings located upstream of Fluid Bar are given in Table 1. Use of recommended straight pipe lengths of uniform diameter ensures that the flow measurement will be made with fully developed characteristics.
Included gate, globe, & other throttling valves that are partially opened. If the valve is full open, use valves shown for 4 & 5. Values shown are the recommended spacing in terms of internal diameters for normal industrial metering requirements. For laboratory of high accuracy work, add 25% to above values.
- **Flow Conditioners**
Flow conditioner may be used to reduce the length of straight pipe required in many cases. Any flow conditioner used shall be installed in the upstream straight length between the Fluid Bar & disturbance or fittings closest to the Fluid Bar. Unless it can be verified that the flow conditions at the inlet of Fluid Bar shall confirm fully developed profile & are free from swirl.

3.1.1 NPE FBR-61 FLUID BAR

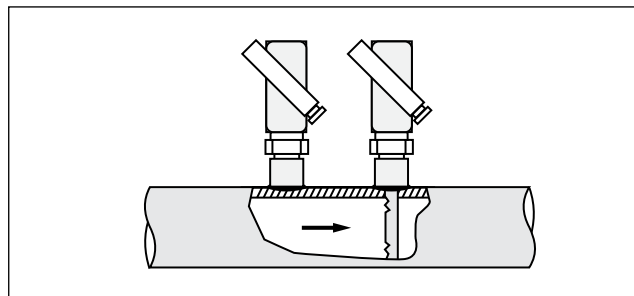

Fig 4: NPE FBR-61 Fluid Bar

3.1.2 TYPE FBR-73 & FBR-75 FLUID BAR

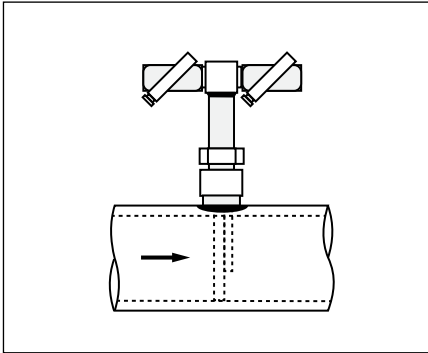

Fig 5: Type FBR-73 Fluid Bar

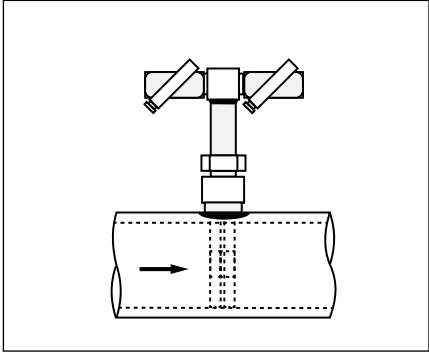

Fig 6: Type FBR-75 Fluid Bar

3.1.3 TYPE FBR-76 FLUID BAR

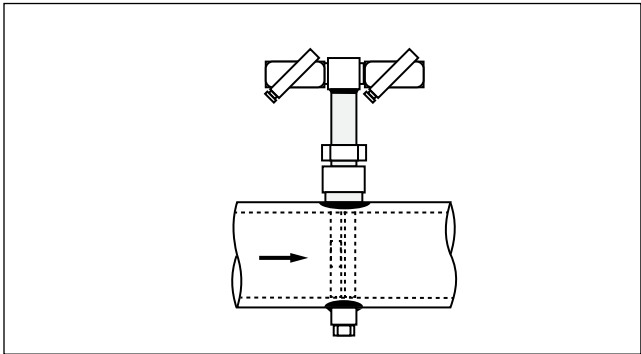

Fig 7: Type FBR-76 Fluid Bar

3.1.4 TYPE FBF-61 FLUID BAR

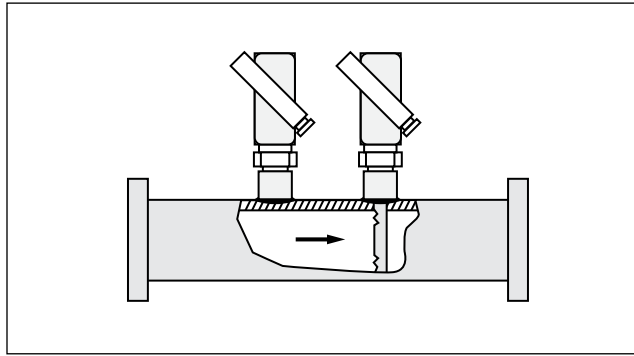

Fig 8: Type FBF-61 Fluid Bar

3.1.5 TYPE FBF-75 & FBF-76 FLUID BAR

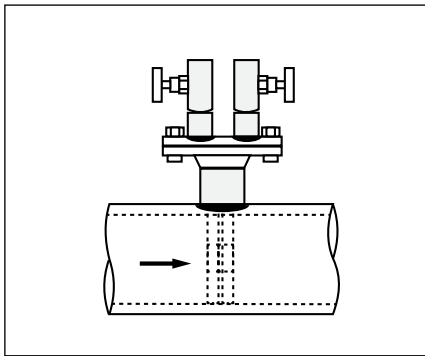

Fig 9: Type FBF-75 Fluid Bar

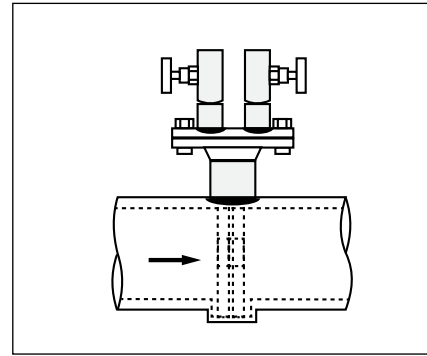

Fig 10: Type FBF-76 Fluid Bar

3.1.6 TYPE FBF-85 FLUID BAR

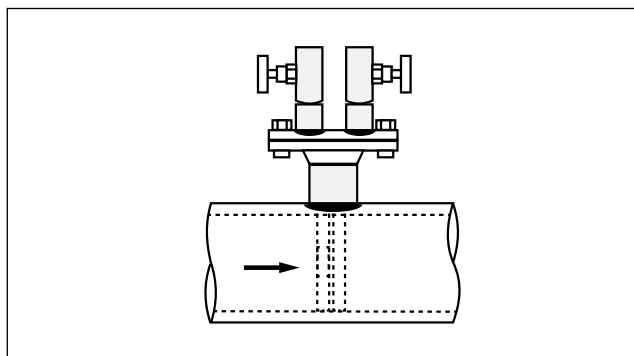

Fig 11: Type FBF-85 Fluid Bar

3.1.7 TYPE FTL-73, FTL-75 & FTL-76 FLUID BAR

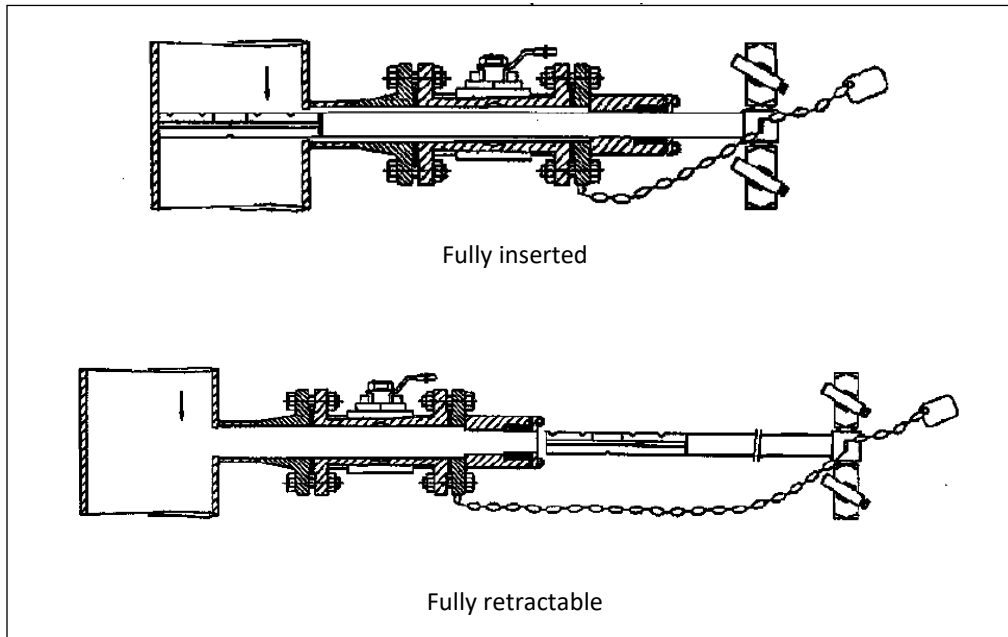

Fig 12: Type FTL-73, FTL-75 & FTL-76 Fluid Bar

3.2 Installation Procedure

1. Verify that the line pressure & temperature are within the rated limits for respective models.
2. Grind off paint or other coatings from the pipe in the area where the Flow-Tap is to be installed. (Except for steam applications, Flow-Tap may be installed at any angle around the pipe.)
3. Drill or bum a 35.0 mm diameter hole in the pipe & for Type FTM-76 & FrH-76 drill or burn a 35.0 rim diameter hole on the opposite side of the pipe for end support.
4. Tack weld the 40 NB weld coupling to the pipe. The coupling must be aligned perpendicular to the pipe axis & square to its plane. For Type FTM-76 & FTH-76, tack weld the end support on the opposite side of the weld coupling. Ensure the end support is aligned perpendicular to the pipe axis & in line with the weld coupling.
5. Install the Flow-Tap unit-isolating valve on the process connection. Verify that the valve is in the fully open position, & that the stem is in line with the pipe to ensure clearance for the insert-retract rods.
6. Install the Flow-Tap cage nipple into the unit-isolating valve.
7. Inspect Flow-Tap assembly to ensure that the insert-retract mechanism is fully retracted.
8. Install the Flow-Tap assembly on the cage nipple. When tight, the flow arrow on the top of the Flow-Tap head must point in the direction of flow.
9. Initiate sensor insertion by rotating the drive nuts clockwise as viewed from the top, using the ratchet wrench supplied with the unit. The nuts must be tightened alternately, about two turns at a time to prevent binding resulting from unequal loading. Continue this procedure until the sensor contacts the opposite side of the pipe or end support.

10. Connect instrument lines to the instrument valves 8 to the appropriate meter, recorder, transmitter w controller.
11. Retract the sensor by rotating the drive nuts counter-clockwise as viewed from the top. The nuts must be turned alternately, about two turns at a time, to prevent binding resulting from unequal loading. Continue this procedure until the sensor is fully retracted.



NOTE

If flow rate higher than 66 lb.ft/sec (90Nm/s) or pipe size larger than 8”(DN400), will require 19mm diameter probe, mounted in 1” ball valve and 1” socket and 22mm hole

4 Electrical Connection

This section covers the all electrical connection requirement. Electrical connection of the device must be carried out by trained, qualified specialists authorized to perform such work by the installation site.



WARNING

-
- Connect all electrical cables when the power is switched off. If the device does not have switch-off elements, then, overcurrent protection devices, lightning protection and/or energy isolating devices must be provided by the customer.
 - The device must be grounded to a spot in accordance with regulations in order to protect personnel against electric shocks.
-



NOTE

-
- When using the measuring device in hazardous areas, installation must comply with the corresponding national standards and regulations and the Safety Instructions or Installation or Control Drawings.
-

4.1 Grounding of Measuring Device

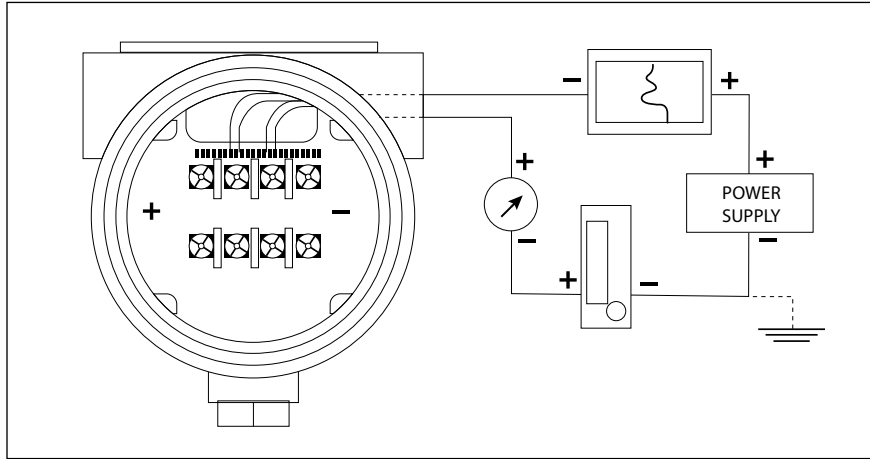

Fig 13: Grounding of Measuring Device

5 Troubleshooting

Fluid Bar operates on natural scientific principles. No moving parts are used in the design, & wear has negligible effect on accuracy. If installed correctly, Fluid Bar will provide a correct flow indication if there is a flow in the pipe. To solve a discrepancy, interpretation of the Fluid Bar signal & other components of the flow system should be examined closely.

Fluid Bar installation - Ensure that the Fluid Bar flow arrow is pointing directly downstream. The Fluid bar accuracy will be influenced by installation misalignment. To ensure meeting stated accuracy, alignment must be within limits shown below.

Pipe size - The Fluid Bar may have been designed for a different pipe size than that in which it is being used. Measure pipes the ID & compare with the size printed on identification tag attached to the Fluid Bar.

Insufficient straight run - If the Fluid Bar is installed in less than recommended straight uniform pipe length, accuracy may be affected. Refer straight run requirements

Calculation - The calculation for a particular Fluid Bar may be in error. Recheck the calculation or graph used for conversion. Changes in operating temperature or pressure are critical for air, gas, or steam applications. Recheck actual operating temperature & pressure compared to values used in the calculation.

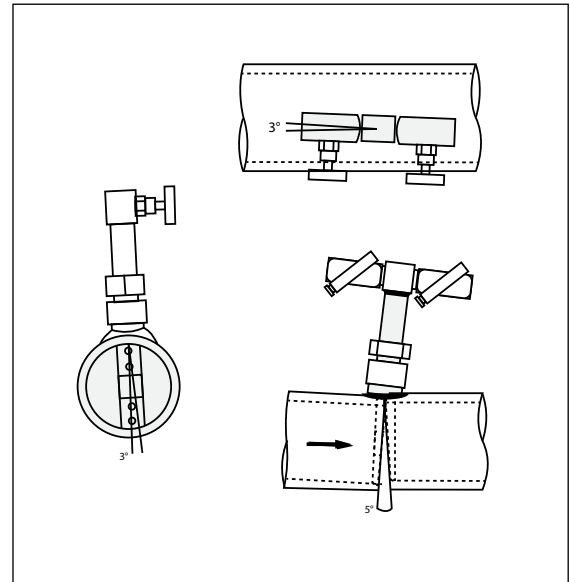

Fig 14: Fluid Bar installation



TEKMATION LLC reserves the right to change the designs and/or materials of its products without notice. The contents of this publication are the property of
TEKMATION and cannot be reproduced by any other party without written permission. All rights reserved. © 2021 TEKMATON LLC
TEKMATION
LLC
DOC/TEK/FORM/211103/1659A1001



www.tek-trol.com

Tek-Trol LLC

796 Tek Drive Crystal Lake, IL 60014, USA

Sales: +1 847-857-6076

Tek-DPro Flow Solutions

PO Box 121 Windsor,
Colorado 80550, USA
Sales: +1 847-857-6076

Tek-Trol Solutions BV

Florijnstraat 18, 4879 AH
Etten-Leur, Netherlands
Sales: +31 76-2031908

Tek-Trol Middle East FZE

SAIF Zone, Y1-067, PO BOX No. 1125,
Sharjah, UAE
Sales: +971-6526-8344

Support: +1 847-857-6076

Email: tektrol@tek-trol.com

www.tek-trol.com

Tek-Trol is a fully owned subsidiary of TEKMATON LLC. We offer our customers a comprehensive range of products and solutions for process, power and oil & gas industries. Tek-Trol provides process measurement and control products for Flow, Level, Temperature & Pressure Measurement, Control Valves & Analyzer systems. We are present in 15 locations globally and are known for our knowledge, innovative solutions, reliable products and global presence.

Flow | Level | Temperature | Pressure | Valves | Analyzers | Accessories | TekValSys